

////// **ZERO-MAX** CD[®] Couplings



**DISTRIBUIDOR
AUTORIZADO**

MEX (55) 53 63 23 31
QRO (442) 1 95 72 60

MTY (81) 83 54 10 18
ventas@industrialmagza.com

- For today's most demanding servo motor and motion control applications. CD Couplings are precise, robust, and available in sizes and models for every application
- High torsional stiffness and high dynamic load capacity ensure reliable machine operation
- Precise positioning under high speed reversing loads without fatigue for reliable 24/7 operation
- Unique patented composite disc design provides misalignment capacity and long operational life
- Clamp style hub design provides a superior method of shaft engagement
- Eco-Friendly, adapted to RoHS Directive with no banned substances



These next-generation CD Couplings allow you to transmit high horsepower in a small envelope. They are ideal for cyclic applications where speed and repeatable accuracy are critical to keep 24/7 systems going.

CD Couplings withstand the punishment and stress of a servo motor. In comparison, other couplings may have high torsional stiffness specifications; however, they can be too brittle to withstand the punishment of high speed reversing applications.

The working part of a CD Coupling is made of high precision composite material. This patented design has high torsional stiffness, and yet allows for misalignment in high stress applications. CD Couplings have excellent chemical and moisture resistance and operate without maintenance in hostile environments.



Standard and Custom CD Couplings are available for every application. Do you need higher misalignment and greater torque capacity in your coupling? Need more flexibility and torsional stiffness? Need a very large bore diameter coupling? Or a long spacer coupling? Zero-Max CD Couplings are available in a full range of styles, models and sizes to meet those needs. Zero-Max will design and build a custom CD Coupling to handle your unique application.



CD® COUPLINGS FOR THE MOST DIFFICULT MOTION APPLICATIONS

- Available in single disc, double disc, stainless steel, floating shaft and custom models
- Single and double disk models available in aluminum clamp style hubs
- Operating temperature range is -70° to +250° F (- 57° to + 121°C)
- Composite discs are resistant to many chemicals
- Hubs are machined to a high level of concentricity for smooth and quiet operation
- Maintenance free
- Ideal for high precision applications including packaging machines, pick and place systems, printing machinery, machine tools and most systems using servo motors
- RoHS compliant – manufactured of RoHS compliant materials and contains no banned substances

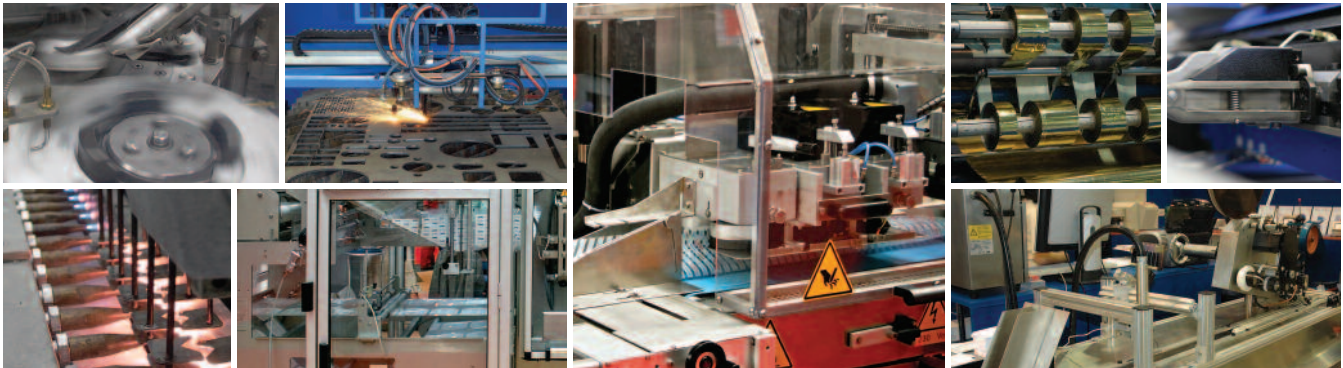
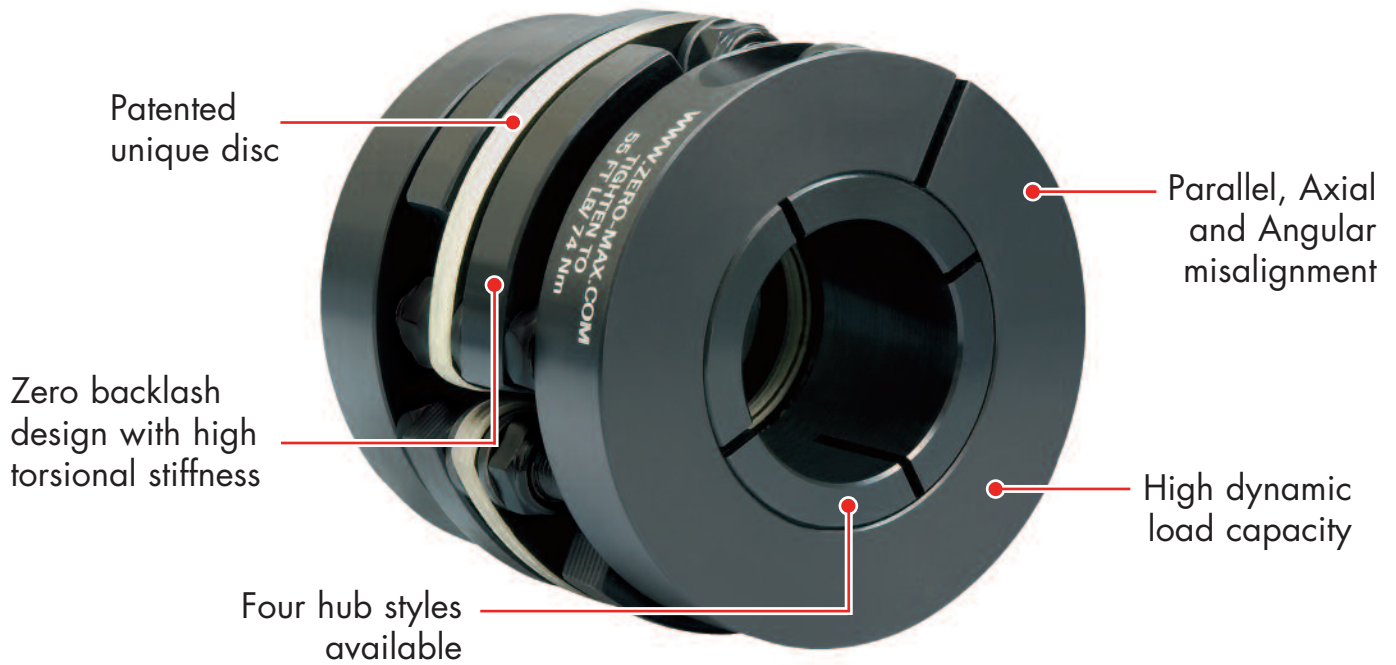

CD[®] COUPLINGS **SINGLE FLEX STEEL**

The Single Flex Composite Disc Coupling is an excellent choice for zero backlash applications. The unique design delivers two features that are not often found in a precision coupling. High torsional stiffness and high durability!

The compact size and clamping system allow this coupling to fit into many applications. This design is also capable of being used in very high speed applications with some modification.

- Zero Backlash
- Torsionally Stiff
- Excellent for Reversing Loads
- Smooth Operation at High Speeds
- Compact



Available with or without keyway on clamp style hubs.

Performance Information

| | Continuous Rated Torque | Peak Rated Torque | Torsional Stiffness | Maximum Speed | | Misalignments | | | A Hub | | B Hub | | Clamped Hub | | QD Hubs |
|-------------------------|-------------------------|--------------------|------------------------|---------------|-----------------|---------------|-----------------|----------------|-------------------------|--|-------------------------|--|-------------------------|--|------------------------|
| | | | | A & B Hub | Clamp Style Hub | Angular | Parallel | Axial | Unit Weight at Max Bore | Unit Inertia at Max Bore | Unit Weight at Max Bore | Unit Inertia at Max Bore | Unit Weight at Max Bore | Unit Inertia at Max Bore | Unit Weight w/ Bushing |
| | in-lbs (Nm) | in-lbs (Nm) | in-lbs/Deg. (Nm/Rad) | (RPM) | (RPM) | Degrees | Inch (mm) | Inch (mm) | Lb. (kg.) | lb-in ² (kg-cm ²) | Lb. (kg.) | lb-in ² (kg-cm ²) | Lb. (kg.) | lb-in ² (kg-cm ²) | Lb. (kg.) |
| 6A18 6A18C | 180 (20) | 360 (40) | 1,800 (11,650) | 14,000 | 12,000 | 3 | 0.004 (0.10) | 0.030 (0.8) | 0.43 (0.2) | 0.16 (0.47) | - | - | 0.82 (0.37) | 0.35 (1.02) | - |
| 6A22 6A22C | 270 (30) | 540 (60) | 2,680 (17,352) | 12,000 | 11,000 | 3 | 0.006 (0.15) | 0.036 (0.9) | 0.88 (0.4) | 0.49 (1.45) | 0.96 (0.44) | 0.66 (1.92) | 1.57 (0.71) | 1.08 (3.16) | - |
| 6A26 6A26C | 475 (53) | 950 (106) | 3,100 (20,100) | 10,500 | 9,500 | 3 | 0.008 (0.20) | 0.043 (1.1) | 1.37 (0.62) | 0.93 (2.72) | 1.37 (0.62) | 1.21 (3.54) | 1.83 (0.83) | 1.57 (4.58) | - |
| 6A30 6A30C | 800 (90) | 1,600 (180) | 6,638 (42,976) | 9,000 | 8,000 | 3 | 0.010 (0.3) | 0.050 (1.3) | 2.0 (0.9) | 1.9 (5.5) | 2.5 (1.1) | 2.8 (8.3) | 3.51 (1.59) | 4.07 (11.90) | - |
| 6A37 6A37C 6A37QD | 1,600 (181) | 3,200 (362) | 10,374 (67,167) | 7,400 | 6,700 | 3 | 0.013 (0.3) | 0.070 (1.8) | 3.6 (1.6) | 5.6 (16.3) | 4.2 (1.9) | 7.9 (23.0) | 6.00 (2.72) | 11.69 (34.19) | 3.7 (1.7) |
| 6A45 6A45C 6A45QD | 2,500 (282) | 5,000 (564) | 19,138 (123,909) | 6,100 | 5,600 | 3 | 0.015 (0.4) | 0.090 (2.3) | 6.4 (2.9) | 14.6 (42.7) | 7.2 (3.3) | 20.0 (58.5) | 10.58 (4.80) | 21.2 (62.0) | 6.8 (3.1) |
| 6A52 6A52C 6A52QD | 3,560 (402) | 7,120 (804) | 26,049 (168,656) | 5,200 | 4,800 | 3 | 0.018 (0.5) | 0.110 (2.8) | 10.5 (4.8) | 32.4 (94.8) | 11.4 (5.2) | 43.2 (126) | 14.65 (6.64) | 53.0 (155.1) | 11.7 (5.3) |
| 6A60 6A60C 6A60QD | 6,350 (718) | 12,700 (1,436) | 41,485 (268,595) | 4,600 | 4,400 | 3 | 0.020 (0.5) | 0.130 (3.3) | 15.3 (7.0) | 61.3 (179) | 18.4 (8.4) | 90.6 (265) | 23.2 (10.5) | 116.4 (340.4) | 15.8 (7.2) |
| 6A67 6A67C 6A67QD | 10,300 (1,164) | 20,600 (2,328) | 61,948 (401,084) | 4,300 | 4,100 | 3 | 0.022 (0.6) | 0.150 (3.8) | 22.0 (10.0) | 111 (325) | 26.5 (12.0) | 163 (477) | 35.0 (15.9) | 205.0 (600.0) | 20.5 (9.3) |
| 6A77 6A77QD | 15,600 (1,763) | 31,200 (3,526) | 94,107 (609,303) | 3,900 | - | 3 | 0.025 (0.6) | 0.160 (4.6) | 31.3 (14.2) | 209 (612) | 38.5 (17.5) | 318 (931) | - | - | 29.5 (13.4) |
| 6A90 | 25,000 (2,825) | 50,000 (5,650) | 160,653 (1,040,162) | 3,600 | - | 3 | 0.030 (0.8) | 0.180 (4.6) | 49.9 (22.7) | 461 (1,349) | 62.6 (28.5) | 722 (2,113) | - | - | - |
| 6A105 | 34,900 (3,944) | 69,800 (7,888) | 244,204 (1,581,120) | 3,300 | - | 3 | 0.035 (0.9) | 0.210 (5.3) | 81.5 (37.0) | 1,046 (3,061) | 98.3 (44.7) | 1,572 (4,600) | - | - | - |
| 6A120 | 47,200 (5,333) | 94,400 (10,666) | 328,095 (2,124,275) | 3,000 | - | 3 | 0.040 (1.0) | 0.250 (6.4) | 124.0 (56.4) | 2,054 (6,011) | 141.0 (64.1) | 3,100 (9,070) | - | - | - |

- Consult factory for speeds higher than those listed and balancing requirements, if necessary.
- Consult factory for higher torque and higher torsional stiffness couplings.



DISTRIBUIDOR MEX (55) 53 63 23 31 MTY (81) 83 54 10 18
 AUTORIZADO QRO (442) 1 95 72 60 ventas@industrialmagza.com

CD® COUPLINGS **SINGLE FLEX STEEL**

Clamp Style Hub

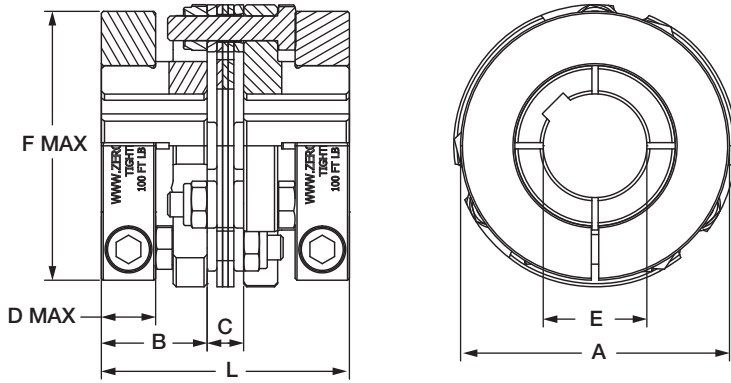

Dimensional Information

| | A | B | C | D | Max Bore E | | F | L |
|-------|--------------|-------------|-------------|------------|------------|------------|------------|--------------|
| | | | | | w/kwy | w/o kwy | | |
| | Inch (mm) | Inch (mm) | Inch (mm) | Inch (mm) | Inch (mm) | Inch (mm) | Inch (mm) | Inch (mm) |
| 6A18C | 1.85 (47.0) | 0.81 (20.6) | 0.28 (7.1) | 0.472 (12) | 0.63 (16) | 0.813 (21) | 1.77 (45) | 1.88 (47.8) |
| 6A22C | 2.25 (57.2) | 1.00 (25.4) | 0.31 (7.9) | 0.551 (14) | 0.75 (20) | 0.938 (25) | 2.21 (56) | 2.31 (58.7) |
| 6A26C | 2.60 (66.0) | 1.06 (26.9) | 0.31 (7.9) | 0.551 (14) | 1.00 (24) | 1.188 (30) | 2.36 (60) | 2.43 (61.7) |
| 6A30C | 3.00 (76.2) | 1.25 (31.8) | 0.46 (11.7) | 0.709 (18) | 1.12 (30) | 1.37 (35) | 2.92 (74) | 2.96 (75.2) |
| 6A37C | 3.75 (95.3) | 1.44 (36.6) | 0.52 (13.2) | 0.748 (19) | 1.50 (38) | 1.87 (48) | 3.71 (94) | 3.40 (86.4) |
| 6A45C | 4.50 (114.3) | 1.69 (42.9) | 0.58 (14.7) | 0.866 (22) | 1.75 (45) | 2.25 (55) | 4.29 (109) | 3.96 (100.6) |
| 6A52C | 5.25 (133.4) | 1.94 (49.3) | 0.65 (16.5) | 0.984 (25) | 2.25 (60) | 2.62 (65) | 4.92 (125) | 4.52 (114.8) |
| 6A60C | 6.00 (152.4) | 2.44 (62.0) | 0.77 (19.6) | 1.339 (34) | 2.62 (70) | 3.00 (75) | 5.71 (145) | 5.64 (143.3) |
| 6A67C | 6.75 (171.5) | 2.75 (69.9) | 0.86 (21.8) | 1.339 (34) | 2.875 (80) | 3.50 (90) | 6.50 (165) | 6.36 (161.5) |

Performance Note: The torque capacity of keyless clamped hubs is governed by many factors, including shaft hub bore diameter, clamp size, and other installation variables. Keyless coupling hubs with bore sizes less than approximately one-half the maximum bore listed may not transmit the torque rating of the coupling. Consult factory if your application is of high torque/small keyless shaft variety.

Set Screw and QD Style Hub

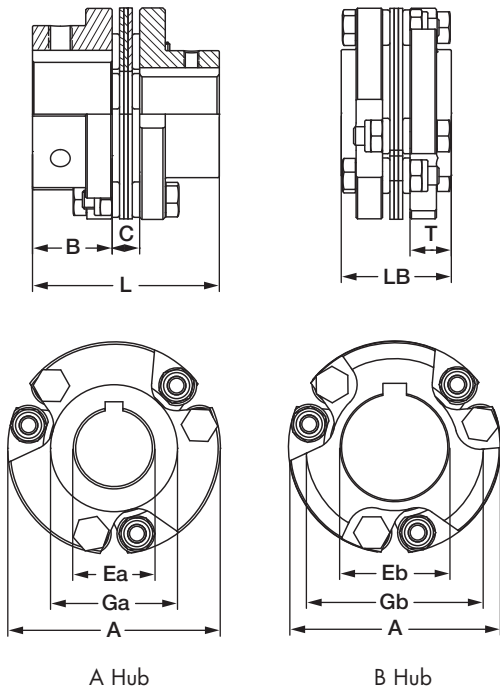

Dimensional Information

| | A | B | C | Max Bore | Max Bore | Ga | Gb | H | L | X | LB | T | QD |
|-------|-------------|--------------|-------------|-------------|-------------|-------------|-------------|-------------|-------------|-------------|-------------|-------------|--------------|
| | | | | A Hub | B Hub | | | | | | | | |
| | Inch (mm) | Inch (mm) | Inch (mm) | Inch (mm) | Inch (mm) | Inch (mm) | Inch (mm) | Inch (mm) | Inch (mm) | Inch (mm) | Inch (mm) | Inch (mm) | Bushing Type |
| 6A18 | 1.85 (47.0) | 0.625 (15.9) | 0.276 (7.0) | 0.625 (16) | - | 1.13 (28.6) | - | 0.79 (20.1) | 1.53 (38.8) | 0.0 (0) | - | - | - |
| 6A22 | 2.25 (57.2) | 0.94 (23.8) | 0.31 (7.8) | 0.625 (16) | 1.000 (26) | 1.22 (31) | 1.88 (47.6) | 0.91 (23.1) | 2.18 (55.4) | 0.51 (13) | - | - | - |
| 6A26 | 2.59 (66) | 1.06 (27.0) | 0.31 (7.8) | 0.750 (19) | 1.250 (32) | 1.50 (38.2) | 2.16 (54.8) | 1.00 (25.4) | 2.43 (61.7) | 0.39 (9.9) | - | - | - |
| 6A30 | 3.00 (76.2) | 1.25 (31.8) | 0.46 (11.7) | 1.000 (25) | 1.375 (35) | 1.71 (43) | 2.50 (64) | 1.21 (31) | 2.96 (75) | 0.39 (9.9) | - | - | - |
| 6A37 | 3.75 (95.3) | 1.44 (36.5) | 0.52 (13.3) | 1.250 (32) | 1.813 (46) | 2.19 (56) | 3.13 (79) | 1.51 (38) | 3.40 (86) | 0.68 (17.3) | 1.78 (45.2) | 0.63 (16) | JA |
| 6A45 | 4.50 (114) | 1.69 (42.9) | 0.58 (14.8) | 1.625 (42) | 2.250 (60) | 2.69 (68) | 3.75 (95) | 1.81 (46) | 3.96 (101) | 0.91 (23.1) | 2.34 (59.5) | 0.88 (22.4) | SH |
| 6A52 | 5.25 (133) | 1.94 (49.2) | 0.65 (16.4) | 1.875 (45) | 2.625 (66) | 3.31 (84) | 4.38 (111) | 2.10 (54) | 4.52 (115) | 0.73 (18.5) | 3.41 (87) | 1.38 (35.1) | SD |
| 6A60 | 6.00 (152) | 2.44 (61.9) | 0.77 (19.5) | 2.250 (60) | 3.000 (76) | 3.67 (93) | 5.00 (127) | 2.42 (61) | 5.64 (143) | 0.69 (17.5) | 3.53 (90) | 1.38 (35.1) | SD |
| 6A67 | 6.75 (172) | 2.75 (69.9) | 0.86 (21.8) | 2.625 (65) | 3.375 (85) | 4.29 (109) | 5.63 (143) | 2.72 (69) | 6.36 (162) | 0.41 (10.4) | 3.62 (92) | 1.38 (35.1) | SK |
| 6A77 | 7.75 (197) | 3.13 (79.4) | 1.01 (25.7) | 2.875 (75) | 3.875 (100) | 4.61 (117) | 6.46 (164) | 3.13 (79) | 7.26 (185) | 0.89 (22.6) | 4.01 (102) | 1.50 (38.1) | SF |
| 6A90 | 9.00 (229) | 3.75 (95.3) | 1.13 (28.8) | 3.000 (75) | 4.500 (120) | 5.38 (137) | 7.50 (191) | 3.62 (92) | 8.63 (219) | 1.39 (35.3) | - | - | - |
| 6A105 | 10.50 (267) | 4.25 (108) | 1.45 (36.8) | 3.750 (95) | 5.125 (130) | 6.11 (155) | 8.75 (222) | 4.23 (107) | 9.95 (253) | 1.92 (48.8) | - | - | - |
| 6A120 | 12.00 (305) | 4.75 (121) | 1.54 (39.0) | 4.250 (110) | 6.000 (152) | 7.34 (186) | 10.00 (254) | 4.83 (123) | 11.04 (280) | 1.48 (37.6) | - | - | - |

• "X" dimension is the minimum bolt travel required beyond the hub to disassemble the disc pack from the hubs.

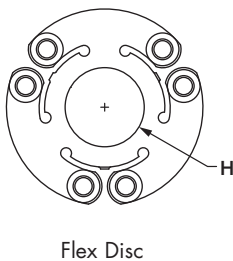

Flex Disc

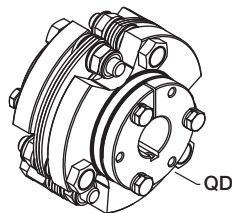

QD Style Hub

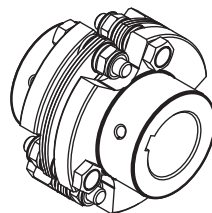

Set Screw Hub



QD Style Hub



Set Screw Hub

CD® COUPLINGS SINGLE FLEX ALUMINUM

The Aluminum hub version of our Single Flex Composite Disc Coupling has very low weight and inertia, making it an excellent choice for servo motor applications. The unique design delivers two features that are not often found in a precision coupling. High torsional stiffness and high durability!

The compact size, low inertia, and clamping system enable this coupling to fit into many applications.

- Zero Backlash
- Torsionally Stiff
- Excellent for Reversing Loads
- Smooth Operation at High Speeds
- Compact



Available with or without keyway on clamp style hubs.

- Consult factory for speeds higher than those listed and balancing requirements, if necessary.
- Consult factory for higher torque and higher torsional stiffness couplings.

| Performance Information | | | | | | | | | | | |
|-------------------------|-------------------------|-------------------|----------------------|-------------------------------------|---------------|--------------|-------------|-------------|-----------------|--|--|
| | Continuous Rated Torque | Peak Rated Torque | Torsional Stiffness | Maximum Speed Clamp Style Hub (RPM) | Misalignments | | | Clamped Hub | | | |
| | | | | | Angular | Parallel | Axial | Unit Weight | | Unit Inertia | |
| | | | | | | | | at Max Bore | at 1/2 Max Bore | at Max Bore | at 1/2 Max Bore |
| | in-lbs (Nm) | in-lbs (Nm) | in-lbs/Deg. (Nm/Rad) | | Degrees | Inch (mm) | Inch (mm) | Lb. (kg.) | Lb. (kg.) | lb-in ² (kg-cm ²) | lb-in ² (kg-cm ²) |
| 6A18-AC | 180 (20) | 360 (40) | 1,800 (11,650) | 15,000 | 3 | 0.004 (0.10) | 0.030 (0.8) | 0.32 (0.15) | 0.31 (0.14) | 0.15 (0.43) | 0.13 (0.37) |
| 6A22-AC | 270 (30) | 540 (60) | 2,680 (17,352) | 13,500 | 3 | 0.006 (0.15) | 0.036 (0.9) | 0.67 (0.30) | 0.51 (0.23) | 0.50 (1.45) | 0.31 (0.90) |
| 6A26-AC | 475 (53) | 950 (106) | 3,100 (20,100) | 11,500 | 3 | 0.008 (0.20) | 0.043 (1.0) | 0.77 (0.35) | 0.66 (0.30) | 0.68 (1.98) | 0.45 (1.32) |
| 6A30-AC | 800 (90) | 1,600 (180) | 6,638 (42,976) | 9,500 | 3 | 0.010 (0.3) | 0.050 (1.3) | 1.46 (0.66) | 1.03 (0.47) | 1.78 (5.21) | 1.04 (3.04) |
| 6A37-AC | 1,600 (181) | 3,200 (362) | 10,374 (67,167) | 8,000 | 3 | 0.013 (0.3) | 0.070 (1.8) | 2.58 (1.17) | 1.74 (0.79) | 5.17 (15.12) | 2.82 (8.26) |
| 6A45-AC | 2,500 (282) | 5,000 (564) | 19,138 (123,909) | 6,700 | 3 | 0.015 (0.4) | 0.090 (2.3) | 4.50 (2.04) | 3.23 (1.46) | 10.00 (29.26) | 7.26 (21.24) |
| 6A52-AC | 3,560 (402) | 7,120 (804) | 26,049 (168,656) | 5,800 | 3 | 0.018 (0.5) | 0.110 (2.8) | 6.07 (2.75) | 5.01 (2.27) | 18.9 (55.2) | 14.8 (43.4) |
| 6A60-AC | 6,350 (718) | 12,700 (1,436) | 41,485 (268,595) | 5,200 | 3 | 0.020 (0.5) | 0.130 (3.3) | 9.74 (4.42) | 7.64 (3.46) | 40.3 (117.8) | 28.3 (82.7) |

Clamp Style Hub

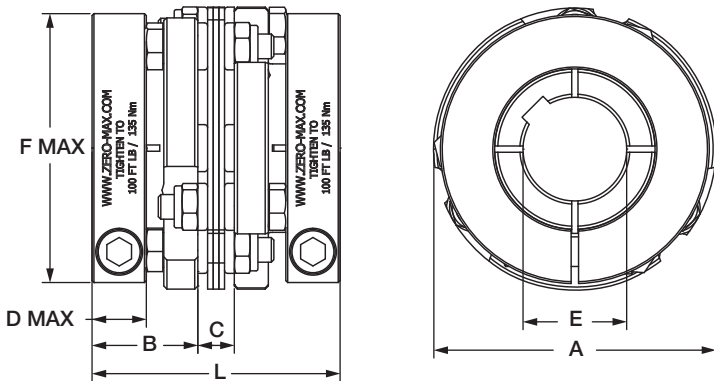

Dimensional Information

| | A | B | C | D | Max Bore | | F | L |
|---------|--------------|-------------|-------------|------------|-----------|------------|------------|--------------|
| | | | | | E | | | |
| | | | | | w/kwy | w/o kwy | | |
| | Inch (mm) | Inch (mm) | Inch (mm) | Inch (mm) | Inch (mm) | Inch (mm) | Inch (mm) | Inch (mm) |
| 6A18-AC | 1.85 (47.0) | 0.81 (20.6) | 0.28 (7.1) | 0.472 (12) | 0.63 (16) | 0.813 (21) | 1.77 (45) | 1.88 (47.8) |
| 6A22-AC | 2.25 (57.2) | 1.00 (25.4) | 0.31 (7.9) | 0.551 (14) | 0.75 (20) | 0.938 (25) | 2.21 (56) | 2.31 (58.7) |
| 6A26-AC | 2.60 (66.0) | 1.06 (26.9) | 0.31 (7.9) | 0.551 (14) | 1.00 (24) | 1.188 (30) | 2.36 (60) | 2.43 (61.7) |
| 6A30-AC | 3.00 (76.2) | 1.25 (31.8) | 0.46 (11.7) | 0.709 (18) | 1.12 (30) | 1.37 (35) | 2.92 (74) | 2.96 (75.2) |
| 6A37-AC | 3.75 (95.3) | 1.44 (36.6) | 0.52 (13.2) | 0.748 (19) | 1.50 (38) | 1.87 (48) | 3.71 (94) | 3.40 (86.4) |
| 6A45-AC | 4.50 (114.3) | 1.69 (42.9) | 0.58 (14.7) | 0.866 (22) | 1.75 (45) | 2.25 (55) | 4.29 (109) | 3.96 (100.6) |
| 6A52-AC | 5.25 (133.4) | 1.94 (49.3) | 0.65 (16.5) | 0.984 (25) | 2.25 (60) | 2.62 (65) | 4.92 (125) | 4.52 (114.8) |
| 6A60-AC | 6.00 (152.4) | 2.44 (62.0) | 0.77 (19.6) | 1.339 (34) | 2.62 (70) | 3.00 (75) | 5.71 (145) | 5.64 (143.3) |

Performance Note: The torque capacity of keyless clamped hubs is governed by many factors, including shaft hub bore diameter, clamp size, and other installation variables. Keyless coupling hubs with bore sizes less than approximately one-half the maximum bore listed may not transmit the torque rating of the coupling. Consult factory if your application is of high torque/small shaft variety.

CD[®] COUPLINGS **SINGLE FLEX** STAINLESS STEEL

The Single Flex Composite Disc Stainless Steel coupling is an excellent choice for zero backlash applications that require stainless steel. The hub and hardware are made from 300 Series stainless steel and the composite disc material is highly resistant to many harsh chemicals.

If your needs require a size of coupling that is not shown below, please contact Zero-Max.



- Consult factory for speeds higher than those listed and balancing requirements, if necessary.
- Consult factory for higher torque and higher torsional stiffness couplings.

| Performance Information | | | | | | | | | | | | | |
|-------------------------|-------------------------|-------------------|----------------------|---------------|-----------------|---------------|-------------|-------------|-------------------------|--------------------------|--|--------------------------|--|
| | Continuous Rated Torque | Peak Rated Torque | Torsional Stiffness | Maximum Speed | | Misalignments | | | A Hub | | Clamped Hub | | |
| | | | | A & B Hub | Clamp Style Hub | Angular | Parallel | Axial | Unit Weight at Max Bore | Unit Inertia at Max Bore | Unit Weight at Max Bore | Unit Inertia at Max Bore | |
| | in-lbs (Nm) | in-lbs (Nm) | in-lbs/Deg. (Nm/Rad) | (RPM) | (RPM) | Degrees | Inch (mm) | Inch (mm) | | Lb. (kg.) | lb-in ² (kg-cm ²) | Lb. (kg.) | lb-in ² (kg-cm ²) |
| 6A30-SS 6A30C-SS | 800 (90) | 1,600 (181) | 6,638 (42,976) | 9,000 | 8,000 | 3 | 0.010 (0.3) | 0.050 (1.3) | 2.0 (0.9) | 1.9 (5.5) | 2.88 (1.31) | 3.11 (9.11) | |
| 6A37-SS 6A37C-SS | 1,600 (181) | 3,200 (362) | 10,374 (67,167) | 7,400 | 6,700 | 3 | 0.013 (0.3) | 0.070 (1.8) | 3.6 (1.6) | 5.6 (16.3) | 6.04 (2.74) | 9.62 (28.13) | |
| 6A45-SS 6A45C-SS | 2,500 (282) | 5,000 (564) | 19,138 (123,909) | 6,100 | 5,600 | 3 | 0.015 (0.4) | 0.090 (2.3) | 6.4 (2.9) | 14.6 (42.7) | 7.65 (3.47) | 18.0 (52.6) | |
| 6A52-SS 6A52C-SS | 3,560 (402) | 7,120 (804) | 26,049 (168,656) | 5,200 | 4,800 | 3 | 0.018 (0.5) | 0.110 (2.8) | 10.5 (4.8) | 32.4 (94.8) | 11.93 (5.41) | 38.9 (113.8) | |

Clamp Style Hub

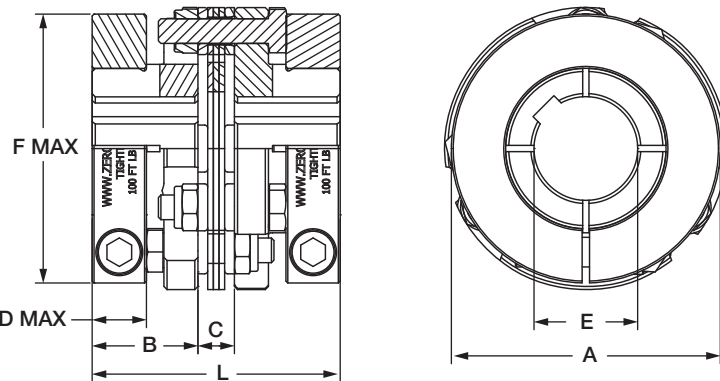

Dimensional Information

| | A | B | C | D | Max Bore | | F | L |
|----------|--------------|-------------|-------------|-------------|-----------|-----------|--------------|--------------|
| | | | | | E w/kwy | E w/o kwy | | |
| | Inch (mm) | Inch (mm) | Inch (mm) | Inch (mm) | Inch (mm) | Inch (mm) | Inch (mm) | Inch (mm) |
| 6A30C-SS | 3.00 (76.2) | 1.25 (31.8) | 0.46 (11.7) | 0.69 (17.5) | 1.12 (28) | 1.37 (35) | 2.63 (66.8) | 2.96 (75.2) |
| 6A37C-SS | 3.75 (95.3) | 1.44 (36.6) | 0.52 (13.2) | 0.75 (19.1) | 1.50 (38) | 1.87 (48) | 3.25 (82.6) | 3.40 (86.4) |
| 6A45C-SS | 4.50 (114.3) | 1.69 (42.9) | 0.58 (14.7) | 0.75 (19.1) | 1.62 (42) | 2.00 (50) | 3.50 (88.9) | 3.96 (100.6) |
| 6A52C-SS | 5.25 (133.4) | 1.94 (49.3) | 0.65 (16.5) | 0.88 (22.4) | 2.12 (55) | 2.62 (65) | 4.25 (108.0) | 4.52 (114.8) |

Performance Note: The torque capacity of keyless clamped hubs is governed by many factors, including shaft hub bore diameter, clamp size, and other installation variables. Keyless coupling hubs with bore sizes less than approximately one-half the maximum bore listed may not transmit the torque rating of the coupling. Consult factory if your application is of high torque/small shaft variety.

Set Screw Style Hub

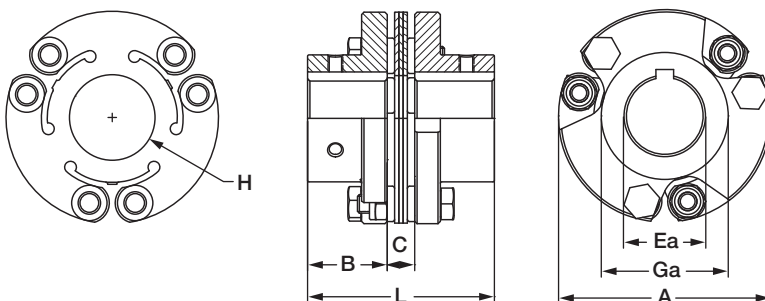

Dimensional Information

| | A | B | C | Max Bore Ea A Hub | Ga A Hub | H | L | X |
|---------|-------------|-------------|-------------|-------------------|-----------|-----------|------------|-------------|
| | | | | | | | | |
| 6A30-SS | 3.00 (76.2) | 1.25 (31.8) | 0.46 (11.7) | 1.000 (25) | 1.71 (43) | 1.21 (31) | 2.96 (75) | 0.39 (9.9) |
| 6A37-SS | 3.75 (95.3) | 1.44 (36.5) | 0.52 (13.3) | 1.250 (32) | 2.19 (56) | 1.51 (38) | 3.40 (86) | 0.68 (17.3) |
| 6A45-SS | 4.50 (114) | 1.69 (42.9) | 0.58 (14.8) | 1.625 (42) | 2.69 (68) | 1.81 (46) | 3.96 (101) | 0.91 (23.1) |
| 6A52-SS | 5.25 (133) | 1.94 (49.2) | 0.65 (16.4) | 1.875 (45) | 3.31 (84) | 2.10 (54) | 4.52 (115) | 0.73 (18.5) |

• "X" dimension is the minimum bolt travel required beyond the hub to disassemble the disc pack from the hubs.

CD® COUPLINGS **DOUBLE FLEX STEEL**

The Double Flex Composite Disc Coupling is ideal for precision applications that require more misalignment capacity than our Single Flex design. The coupling's large misalignment capacity, high torsional stiffness, and overall high performance specifications make this coupling a good choice for a wide variety of applications.



- Zero Backlash
- Torsionally Stiff
- Excellent for Reversing Loads
- Smooth Operation at High Speeds
- Compact
- Very low reaction loads on shaft bearings due to misalignment

Available with or without keyway on clamp style hubs.

| Performance Information | | | | | | | | | | | | | | | |
|-------------------------|-------------------------|-------------------|----------------------|---------------|-----------------|---------------|--------------|--------------|-------------------------|--|-------------------------|--|-------------------------|--|-----------------------|
| | Continuous Rated Torque | Peak Rated Torque | Torsional Stiffness | Maximum Speed | | Misalignments | | | A Hub | | B Hub | | Clamped Hub | | QD Hubs |
| | | | | A & B Hub | Clamp Style Hub | Angular | Parallel | Axial | Unit Weight at Max Bore | Unit Inertia at Max Bore | Unit Weight at Max Bore | Unit Inertia at Max Bore | Unit Weight at Max Bore | Unit Inertia at Max Bore | Unit Weight w/Bushing |
| | in-lbs (Nm) | in-lbs (Nm) | in-lbs/Deg. (Nm/Rad) | (RPM) | (RPM) | Degrees | Inch (mm) | Inch (mm) | Lb. (kg.) | lb-in ² (kg-cm ²) | Lb. (kg.) | lb-in ² (kg-cm ²) | Lb. (kg.) | lb-in ² (kg-cm ²) | Lb. (kg.) |
| 6P18 6P18C | 180 (20) | 360 (40) | 850 (5,500) | 14,000 | 12,000 | 3 | 0.022 (0.56) | 0.060 (1.5) | 0.47 (0.21) | 0.19 (0.56) | - | - | 0.93 (0.42) | 0.40 (1.17) | - |
| 6P22 6P22C | 270 (30) | 540 (36) | 1,310 (8,482) | 12,000 | 11,000 | 3 | 0.026 (0.66) | 0.072 (1.8) | 1.10 (0.50) | 0.66 (1.94) | 1.18 (0.54) | 0.82 (2.41) | 1.79 (0.81) | 1.25 (3.65) | - |
| 6P26 6P26C | 475 (53) | 950 (106) | 1,500 (9,712) | 10,500 | 9,500 | 3 | 0.030 (0.76) | 0.086 (2.2) | 1.66 (0.75) | 1.19 (3.47) | 1.66 (0.75) | 1.46 (4.28) | 2.12 (0.96) | 1.82 (5.31) | - |
| 6P30 6P30C | 800 (90) | 1,600 (181) | 3,231 (20,923) | 9,000 | 8,000 | 3 | 0.039 (1.0) | 0.100 (2.5) | 2.5 (1.1) | 2.5 (7.3) | 3.0 (1.3) | 3.5 (10.2) | 4.01 (1.82) | 4.70 (13.75) | - |
| 6P37 6P37C 6P37QD | 1,600 (181) | 3,200 (362) | 5,051 (32,700) | 7,400 | 6,700 | 3 | 0.049 (1.2) | 0.140 (3.6) | 4.5 (2.1) | 7.5 (21.8) | 5.1 (2.3) | 9.8 (28.6) | 6.25 (2.83) | 13.59 (39.74) | 4.0 (1.8) |
| 6P45 6P45C 6P45QD | 2,500 (282) | 5,000 (564) | 9,317 (60,324) | 6,100 | 5,600 | 3 | 0.052 (1.3) | 0.180 (4.6) | 7.9 (3.6) | 19.1 (55.9) | 8.7 (4.0) | 24.5 (71.7) | 12.1 (5.5) | 25.7 (75.0) | 8.1 (3.7) |
| 6P52 6P52C 6P52QD | 3,560 (402) | 7,120 (804) | 12,682 (82,109) | 5,100 | 4,800 | 3 | 0.062 (1.6) | 0.220 (5.6) | 12.8 (5.8) | 41.6 (122) | 13.7 (6.2) | 52.5 (154) | 16.9 (7.6) | 62.3 (182.2) | 13.9 (6.3) |
| 6P60 6P60C 6P60QD | 6,350 (718) | 12,700 (1,436) | 20,196 (130,763) | 4,600 | 4,400 | 3 | 0.069 (1.8) | 0.260 (6.6) | 18.4 (8.4) | 79.3 (232) | 21.5 (9.8) | 109 (319) | 26.3 (11.9) | 134.3 (392.9) | 18.9 (8.6) |
| 6P67 6P67C 6P67QD | 10,300 (1,164) | 20,600 (2,328) | 30,159 (195,265) | 4,300 | 4,100 | 3 | 0.076 (1.9) | 0.300 (7.6) | 26.2 (11.9) | 141 (413) | 30.7 (14.0) | 193 (565) | 39.2 (17.8) | 235 (687) | 24.7 (11.2) |
| 6P77 6P77QD | 15,600 (3,526) | 31,200 (3,526) | 45,815 (296,634) | 3,300 | - | 3 | 0.089 (2.3) | 0.320 (8.1) | 38.5 (17.5) | 273 (799) | 45.8 (20.8) | 381 (1115) | - | - | 36.8 (16.7) |
| 6P90 | 25,000 (2,825) | 50,000 (5,650) | 78,213 (506,395) | 2,800 | - | 3 | 0.101 (2.6) | 0.360 (9.1) | 61.4 (27.9) | 596 (1744) | 74.1 (33.7) | 857 (2508) | - | - | - |
| 6P105 | 34,900 (3,944) | 69,800 (7,888) | 118,889 (769,756) | 2,500 | - | 3 | 0.126 (3.2) | 0.420 (10.7) | 101 (45.9) | 1362 (3986) | 118 (53.6) | 1888 (5525) | - | - | - |
| 6P120 | 47,200 (5,333) | 94,400 (10,666) | 159,730 (1,034,187) | 2,100 | - | 3 | 0.137 (3.5) | 0.500 (12.7) | 150 (68.2) | 2600 (7609) | 167 (76.0) | 3646 (10,670) | - | - | - |

- Consult factory for speeds higher than those listed and balancing requirements, if necessary.
- Consult factory for higher torque and higher torsional stiffness couplings.

CD® COUPLINGS **DOUBLE FLEX STEEL**

Clamp Style Hub

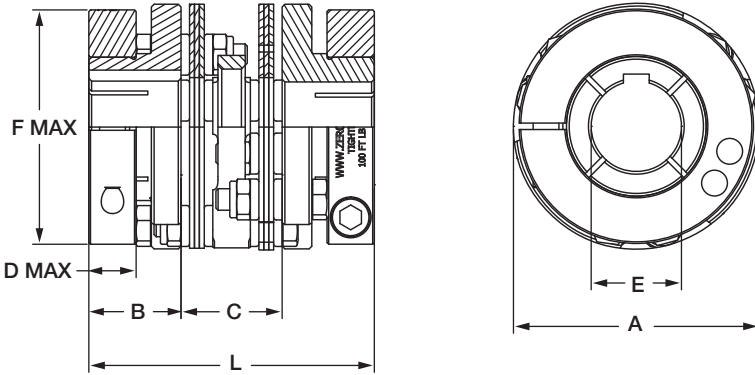

Dimensional Information

| | A | B | C | D | Max Bore | | F | L |
|-------|--------------|-------------|-------------|------------|------------|------------|------------|--------------|
| | | | | | E w/kwy | E w/o kwy | | |
| | Inch (mm) | Inch (mm) | Inch (mm) | Inch (mm) | Inch (mm) | Inch (mm) | Inch (mm) | Inch (mm) |
| 6P18C | 1.85 (47.0) | 0.81 (20.6) | 0.80 (20.3) | 0.472 (12) | 0.63 (16) | 0.813 (21) | 1.77 (45) | 2.42 (61.5) |
| 6P22C | 2.25 (57.2) | 1.00 (25.4) | 0.96 (24.4) | 0.551 (14) | 0.75 (20) | 0.938 (25) | 2.21 (56) | 2.96 (75.2) |
| 6P26C | 2.60 (66.0) | 1.06 (26.9) | 1.04 (26.4) | 0.551 (14) | 1.00 (24) | 1.188 (30) | 2.36 (60) | 3.16 (80.3) |
| 6P30C | 3.00 (76.2) | 1.25 (31.8) | 1.42 (36.1) | 0.709 (18) | 1.12 (30) | 1.37 (35) | 2.92 (74) | 3.92 (99.6) |
| 6P37C | 3.75 (95.3) | 1.44 (36.6) | 1.67 (42.4) | 0.748 (19) | 1.50 (38) | 1.87 (48) | 3.71 (94) | 4.55 (115.6) |
| 6P45C | 4.50 (114.3) | 1.69 (42.9) | 1.85 (47.0) | 0.866 (22) | 1.75 (45) | 2.25 (55) | 4.29 (109) | 5.23 (132.8) |
| 6P52C | 5.25 (133.4) | 1.94 (49.3) | 2.11 (53.6) | 0.984 (25) | 2.25 (60) | 2.62 (65) | 4.92 (125) | 5.98 (151.9) |
| 6P60C | 6.00 (152.4) | 2.44 (62.0) | 2.41 (61.2) | 1.339 (34) | 2.62 (70) | 3.00 (75) | 5.71 (145) | 7.29 (185.2) |
| 6P67C | 6.75 (171.5) | 2.75 (69.9) | 2.70 (68.6) | 1.339 (34) | 2.875 (80) | 3.50 (90) | 6.50 (165) | 8.20 (208.3) |

Performance Note: The torque capacity of keyless clamped hubs is governed by many factors, including shaft hub bore diameter, clamp size, and other installation variables. Keyless coupling hubs with bore sizes less than approximately one-half the maximum bore listed may not transmit the torque rating of the coupling. Consult factory if your application is of high torque/small shaft variety.

Set Screw and QD Style Hub

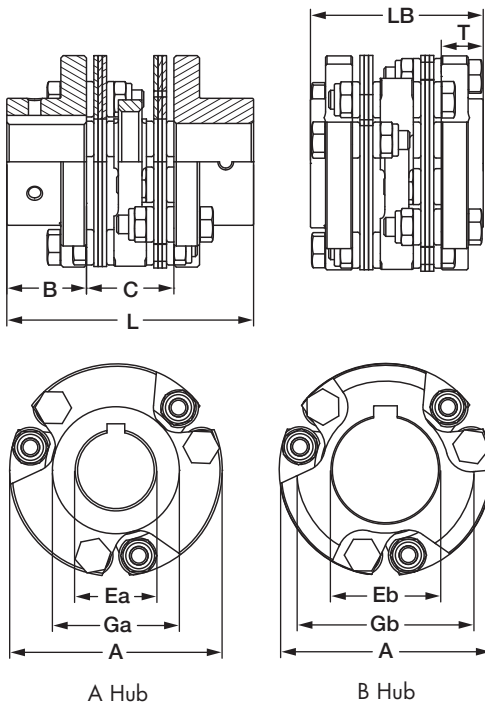

Dimensional Information

| | A | B | C | Max Bore | | Ga | Gb | H | L | X | Y | LB | T | QD |
|-------|-------------|--------------|--------------|-------------|-------------|--------------|-------------|--------------|-------------|-------------|-------------|------------|-------------|------|
| | | | | Ea A Hub | Eb B Hub | | | | | | | | | |
| | Inch (mm) | Inch (mm) | Inch (mm) | Inch (mm) | Inch (mm) | Inch (mm) | Inch (mm) | Inch (mm) | Inch (mm) | Inch (mm) | Inch (mm) | Inch (mm) | Inch (mm) | Type |
| 6P18 | 1.85 (47.0) | 0.625 (15.9) | 0.803 (20.4) | 0.625 (16) | - | 1.125 (28.6) | - | 0.790 (20.1) | 2.05 (52.1) | - | 0.48 (12.2) | - | - | - |
| 6P22 | 2.25 (57.2) | 0.938 (23.8) | 0.956 (24.3) | 0.625 (16) | 1.000 (26) | 1.219 (31) | 1.88 (47.6) | 0.907 (23.3) | 2.83 (71.9) | 0.51 (13) | 0.64 (16.3) | - | - | - |
| 6P26 | 2.59 (65.9) | 1.06 (27) | 1.03 (26.3) | 0.750 (19) | 1.250 (32) | 1.502 (38.2) | 2.16 (54.8) | 1.00 (25.4) | 3.16 (80.2) | 0.39 (9.9) | 0.47 (12) | - | - | - |
| 6P30 | 3.00 (76.2) | 1.25 (31.8) | 1.42 (36.1) | 1.000 (25) | 1.375 (35) | 1.71 (43) | 2.50 (64) | 1.21 (31) | 3.92 (100) | 0.39 (9.9) | 0.68 (17.3) | - | - | - |
| 6P37 | 3.75 (95.3) | 1.44 (36.5) | 1.67 (42.4) | 1.250 (32) | 1.813 (46) | 2.19 (56) | 3.13 (79) | 1.51 (38) | 4.55 (115) | 0.68 (17.3) | 0.95 (24.1) | 2.93 (75) | 0.63 (16) | JA |
| 6P45 | 4.50 (114) | 1.69 (42.9) | 1.85 (47.0) | 1.625 (41) | 2.250 (60) | 2.69 (68) | 3.75 (95) | 1.81 (46) | 5.23 (133) | 0.91 (23.1) | 1.35 (34.3) | 3.61 (92) | 0.88 (22.4) | SH |
| 6P52 | 5.25 (133) | 1.94 (49.2) | 2.11 (53.5) | 1.875 (45) | 2.625 (66) | 3.31 (84) | 4.38 (111) | 2.10 (54) | 5.98 (152) | 0.73 (18.5) | 1.10 (27.9) | 4.87 (124) | 1.38 (35.1) | SD |
| 6P60 | 6.00 (152) | 2.44 (61.9) | 2.41 (61.2) | 2.250 (60) | 3.000 (76) | 3.67 (93) | 5.00 (127) | 2.42 (61) | 7.29 (185) | 0.69 (17.5) | 1.42 (36.1) | 5.17 (131) | 1.38 (35.1) | SD |
| 6P67 | 6.75 (171) | 2.75 (69.9) | 2.70 (68.7) | 2.625 (65) | 3.375 (85) | 4.29 (108) | 5.63 (143) | 2.72 (69) | 8.20 (208) | 0.41 (10.4) | 1.11 (28.2) | 5.46 (139) | 1.38 (35.1) | SK |
| 6P77 | 7.75 (197) | 3.13 (79.4) | 3.15 (80.1) | 2.875 (75) | 3.875 (100) | 4.61 (117) | 6.46 (164) | 3.13 (79) | 9.40 (239) | 0.89 (22.6) | 1.40 (35.6) | 6.15 (156) | 1.38 (35.1) | SF |
| 6P90 | 9.00 (229) | 3.75 (95.3) | 3.58 (91.0) | 3.000 (75) | 4.500 (120) | 5.38 (137) | 7.50 (190) | 3.62 (92) | 11.08 (281) | 1.39 (35.3) | 1.47 (37.3) | - | - | - |
| 6P105 | 10.50 (267) | 4.25 (108) | 4.42 (112) | 3.750 (95) | 5.125 (130) | 6.11 (155) | 8.75 (222) | 4.23 (107) | 12.92 (328) | 1.92 (48.8) | 2.64 (67.1) | - | - | - |
| 6P120 | 12.00 (305) | 4.75 (121) | 4.82 (123) | 4.250 (110) | 6.000 (152) | 7.34 (186) | 10.00 (254) | 4.83 (123) | 14.28 (364) | 1.48 (37.6) | 2.14 (54.4) | - | - | - |

• "X" dimension is the minimum bolt travel required beyond the hub to disassemble the disc pack and intermediate member from the hubs.

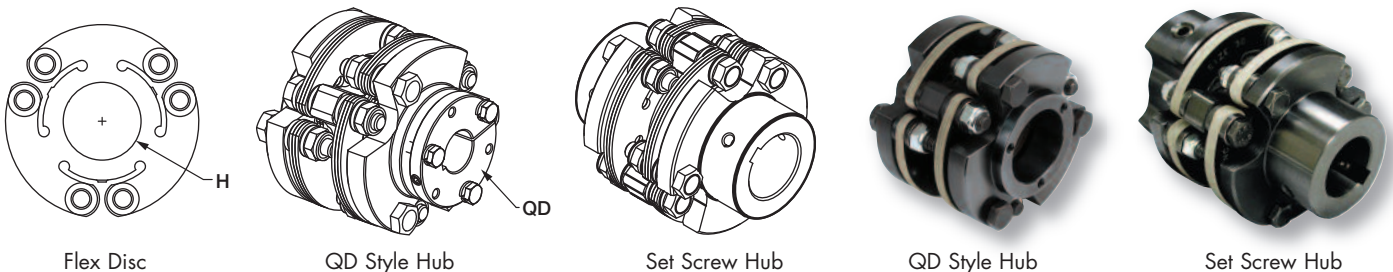

CD® COUPLINGS **DOUBLE FLEX** ALUMINUM

The Double Flex Composite Disc Coupling is ideal for precision applications that require more misalignment capacity than our Single Flex design. The coupling's large misalignment capacity, high torsional stiffness, and overall high performance specifications make this coupling a good choice for a wide variety of applications. Aluminum hubs offer all this with very little inertia.

- Zero Backlash
- Torsionally Stiff
- Excellent for Reversing Loads
- Smooth Operation at High Speeds
- Compact
- Very low reaction loads on shaft bearings due to misalignment



Clamp Style Hub

Available with or without keyway on clamp style hubs.

| Performance Information | | | | | | | | | | | |
|-------------------------|-------------------------|----------------------|----------------------|-------------------------------|---------------|--------------|-------------|-------------|-----------------|--|--|
| | Continuous Rated Torque | Maximum Rated Torque | Torsional Stiffness | Maximum Speed Clamp Style Hub | Misalignments | | | Clamped Hub | | | |
| | | | | | Angular | Parallel | Axial | Unit Weight | | Unit Inertia | |
| | | | | | | | | at Max Bore | at 1/2 Max Bore | at Max Bore | at 1/2 Max Bore |
| | in-lbs (Nm) | in-lbs (Nm) | in-lbs/Deg. (Nm/Rad) | (RPM) | Degrees | Inch (mm) | Inch (mm) | Lb. (kg.) | Lb. (kg.) | lb-in ² (kg-cm ²) | lb-in ² (kg-cm ²) |
| 6P18-AC | 180 (20) | 360 (40) | 850 (5,500) | 15,000 | 3 | 0.022 (0.56) | 0.060 (1.5) | 0.43 (0.20) | 0.43 (0.19) | 0.20 (0.57) | 0.18 (0.51) |
| 6P22-AC | 270 (30) | 540 (60) | 1,310 (8,482) | 11,000 | 3 | 0.026 (0.66) | 0.072 (1.8) | 0.89 (0.40) | 0.73 (0.33) | 0.66 (1.94) | 0.48 (1.39) |
| 6P26-AC | 475 (53) | 950 (106) | 1,500 (9,712) | 9,500 | 3 | 0.030 (0.76) | 0.086 (2.2) | 1.06 (0.48) | 0.95 (0.43) | 0.93 (2.72) | 0.70 (2.05) |
| 6P30-AC | 800 (90) | 1,600 (181) | 3,231 (20,923) | 8,000 | 3 | 0.039 (1.0) | 0.100 (2.5) | 1.96 (0.89) | 1.53 (0.69) | 2.41 (7.05) | 1.67 (4.88) |
| 6P37-AC | 1,600 (181) | 3,200 (362) | 5,051 (32,700) | 6,700 | 3 | 0.049 (1.2) | 0.140 (3.6) | 3.53 (1.60) | 2.69 (1.22) | 7.07 (20.67) | 4.72 (13.81) |
| 6P45-AC | 2,500 (282) | 5,000 (564) | 9,317 (60,324) | 5,600 | 3 | 0.052 (1.3) | 0.180 (4.6) | 6.00 (2.72) | 4.73 (2.15) | 14.5 (42.3) | 11.7 (34.3) |
| 6P52-AC | 3,560 (402) | 7,120 (804) | 12,682 (82,109) | 4,800 | 3 | 0.062 (1.6) | 0.220 (5.6) | 8.28 (3.75) | 7.22 (3.27) | 28.1 (82.3) | 24.1 (70.5) |
| 6P60-AC | 6,350 (718) | 12,700 (1,436) | 20,196 (130,763) | 4,400 | 3 | 0.069 (1.8) | 0.260 (6.6) | 12.8 (5.8) | 10.7 (4.9) | 58.2 (170.3) | 46.2 (135.3) |

- Consult factory for speeds higher than those listed and clamping requirements, if necessary.
- Consult factory for higher torque and higher torsional stiffness couplings.

Clamp Style Hub

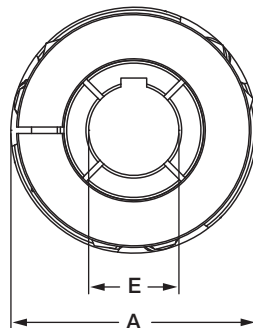
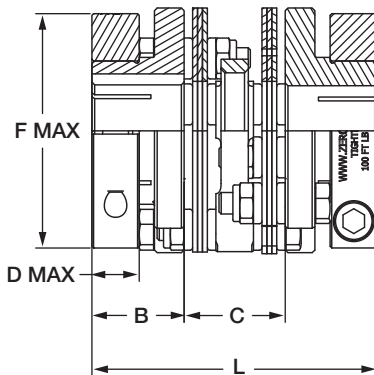

| Dimensional Information | | | | | | | | |
|-------------------------|--------------|-------------|-------------|------------|-----------|------------|------------|--------------|
| | A | B | C | D | Max Bore | | F | L |
| | | | | | E | | | |
| | | | | | w/kwy | w/o kwy | | |
| | Inch (mm) | Inch (mm) | Inch (mm) | Inch (mm) | Inch (mm) | Inch (mm) | Inch (mm) | Inch (mm) |
| 6P18-AC | 1.85 (47.0) | 0.81 (20.6) | 0.80 (20.3) | 0.472 (12) | 0.63 (16) | 0.813 (21) | 1.77 (45) | 2.42 (61.5) |
| 6P22-AC | 2.25 (57.2) | 1.00 (25.4) | 0.96 (24.4) | 0.551 (14) | 0.75 (20) | 0.938 (25) | 2.21 (56) | 2.96 (75.2) |
| 6P26-AC | 2.60 (66.0) | 1.06 (26.9) | 1.04 (26.4) | 0.551 (14) | 1.00 (24) | 1.188 (30) | 2.36 (60) | 3.16 (80.3) |
| 6P30-AC | 3.00 (76.2) | 1.25 (31.8) | 1.42 (36.1) | 0.709 (18) | 1.12 (30) | 1.37 (35) | 2.92 (74) | 3.92 (99.6) |
| 6P37-AC | 3.75 (95.3) | 1.44 (36.6) | 1.67 (42.4) | 0.748 (19) | 1.50 (38) | 1.87 (48) | 3.71 (94) | 4.55 (115.6) |
| 6P45-AC | 4.50 (114.3) | 1.69 (42.9) | 1.85 (47.0) | 0.866 (22) | 1.75 (45) | 2.25 (55) | 4.29 (109) | 5.23 (132.8) |
| 6P52-AC | 5.25 (133.4) | 1.94 (49.3) | 2.11 (53.6) | 0.984 (25) | 2.25 (60) | 2.62 (65) | 4.92 (125) | 5.98 (151.9) |
| 6P60-AC | 6.00 (152.4) | 2.44 (62.0) | 2.41 (61.2) | 1.339 (34) | 2.62 (70) | 3.00 (75) | 5.71 (145) | 7.29 (185.2) |

Performance Note: The torque capacity of keyless clamped hubs is governed by many factors, including shaft hub bore diameter, clamp size, and other installation variables. Keyless coupling hubs with bore sizes less than approximately one-half the maximum bore listed may not transmit the torque rating of the coupling. Consult factory if your application is of high torque/small shaft variety.

CD® COUPLINGS **FLOATING SHAFT**

The Composite Disc Floating Shaft Coupling is zero backlash and torsionally stiff, yet provides superior misalignment capacity. Additionally, the patented Composite Disc provides excellent support for the floating shaft component with very little radial loads on the connected equipment and bearings. Precision hardware and precise machining ensures smooth and accurate operation.

- Zero Backlash
- Torsionally Stiff
- Excellent for Reversing Loads
- Very Low Reaction Loads
- Available in both set screw and clamp style hubs



Available with or without keyway on clamp style hubs.

Performance Information

| | Continuous Rated Torque | Peak Rated Torque | Bse (Note 1) at 12" DBSE (at 300mm DBSE) | Torsional Stiffness | | | | Maximum Misalignments | | | A Hub | | | | B Hub | | Clamped Hub | |
|---------------|-------------------------|-------------------|--|---------------------|---------------|-------------|-------------|-----------------------|--------------------------------------|----------------|--|--|---|--|------------------------------|---|--------------------------------------|---|
| | | | | Factor Z | Factor Y | Factor Z1 | Factor Y1 | Angular (Note 2) | Parallel | Axial | Base Unit Wt. at 12" DBSE (Note 3) at 300mm DBSE | Base Unit Inertia at 12" DBSE (Note 3) at 300mm DBSE | Weight adder per inch of DBSE (per meter of DBSE) | Inertia adder inch of DBSE (per meter of DBSE) | Additional Weight for (each) | Additional Inertia for (each) | Additional Weight for (each) maximum | Additional Inertia for (each) maximum |
| | in.-lbs. (Nm) | in.-lbs. (Nm) | in. lbs./deg. (Nm/Radian) | in.-lbs./deg. | in.-lbs./deg. | (Nm/Radian) | (Nm/Radian) | Degrees | Inch/inch of DBSE (mm/Meter of DBSE) | Inch (mm) | Lb. (kg.) | Lb.-in ² (Kg Cm ² /meter) | Lb./inch (kg./meter) | Lb.-In ² (Kg-Cm ²) | Lb. (kg.) | Lb.-In ² (Kg-Cm ²) | Lb. (kg.) | Lb.-In ² (Kg-Cm ²) |
| 6F22 6F22C | 270 (30) | 540 (60) | 516 (3,379) | 0.05 | 0.84 | (0.338) | (138) | 2.5 | 0.022 (22) | 0.060 (1.5) | 2.00 (0.9) | 0.86 (2.5) | 0.054 (0.97) | 0.012 (1.37) | 0.04 (0.0) | 0.09 (0.2) | 0.32 (0.14) | 0.15 (0.4) |
| 6F26 6F26C | 475 (53) | 950 (106) | 857 (5,589) | 0.09 | 2.09 | (0.559) | (344) | 2.5 | 0.022 (22) | 0.080 (2.0) | 3.29 (1.5) | 1.90 (5.6) | 0.086 (1.54) | 0.029 (3.40) | 0.00 (0.0) | 0.14 (0.4) | 0.40 (0.18) | 0.33 (1.0) |
| 6F30 6F30C | 800 (90) | 1,600 (180) | 1,246 (8,157) | 0.13 | 2.09 | (0.816) | (344) | 2.5 | 0.022 (22) | 0.100 (2.5) | 4.19 (1.9) | 3.44 (10.1) | 0.086 (1.54) | 0.029 (3.40) | 0.25 (0.1) | 0.48 (1.4) | 0.65 (0.3) | 0.77 (2.3) |
| 6F37 6F37C | 1,600 (181) | 3,200 (362) | 3,754 (24,439) | 0.38 | 13.05 | (2.444) | (2,146) | 3 | 0.026 (26) | 0.14 (3.6) | 8.30 (3.8) | 11.8 (34.5) | 0.208 (3.73) | 0.184 (21.2) | 0.30 (0.1) | 1.2 (3.4) | 1.01 (0.5) | 1.90 (5.6) |
| 6F45 6F45C | 2,500 (282) | 5,000 (564) | 7,215 (46,963) | 0.72 | 25.57 | (4.696) | (4,205) | 3 | 0.026 (26) | 0.18 (4.6) | 13.2 (6.0) | 28.2 (82.4) | 0.254 (4.54) | 0.360 (41.6) | 0.42 (0.2) | 2.7 (7.9) | 1.01 (0.5) | 4.6 (13.4) |
| 6F52 6F52C | 3,560 (402) | 7,120 (804) | 9,921 (64,571) | 0.99 | 35.72 | (6.457) | (5,874) | 3 | 0.026 (26) | 0.22 (5.6) | 20.9 (9.5) | 61.1 (179) | 0.292 (5.22) | 0.504 (58.2) | 0.45 (0.2) | 5.4 (15.8) | 3.7 (1.7) | 13.3 (38.8) |
| 6F60 6F60C | 6,350 (718) | 12,700 (1,436) | 15,749 (102,533) | 1.58 | 53.3 | (10.253) | (8,765) | 3 | 0.026 (26) | 0.26 (6.6) | 28.2 (12.8) | 109 (320) | 0.333 (5.97) | 0.751 (86.8) | 1.5 (0.07) | 14.6 (42.8) | 5.0 (2.3) | 15.4 (45.0) |
| 6F67 6F67C | 10,300 (1,164) | 20,600 (2,328) | 24,219 (157,561) | 2.42 | 93.98 | (15.756) | (15,454) | 3 | 0.026 (26) | 0.30 (7.6) | 39.7 (18.0) | 201 (587) | 0.403 (7.21) | 1.325 (153.0) | 2.3 (1.0) | 25.8 (75.5) | 5.6 (2.5) | 18.0 (52.6) |

Note:1) For torsional stiffness (K, in.-lb./deg.) of units longer than 12", use the following formula, where L=(DBSE-12) : $K = ((Z \times Y) / ((L \times Z) + Y)) \times 10^4$.

For torsional stiffness (K, Nm/Radian) of units longer than 300mm, use the following formula, where L=(DBSE-300) : $K = ((Z1 \times Y1) / ((L \times Z1) + Y1)) \times 10^4$.

Note:2) See page 13 regarding selection of coupling and misalignment capability.

Note:3) For weight and inertia of units longer than 12", subtract 12" from the DBSE (dimension C) and multiply by weight/inertia adders listed above.

CD® COUPLINGS **FLOATING SHAFT**



See the following page for maximum C Length and RPM data

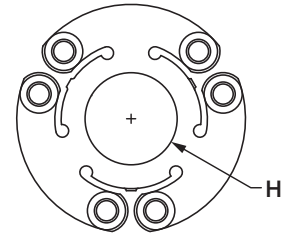
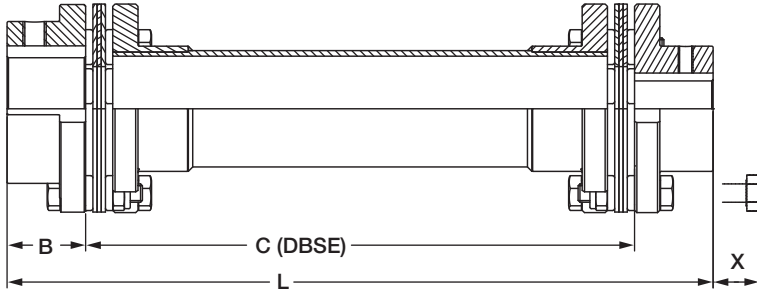

Flex Disc

Set Screw Style Hub

Clamp Style Hub

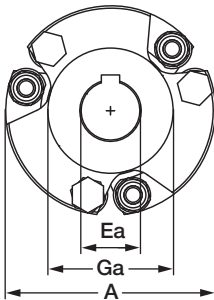

A Hub

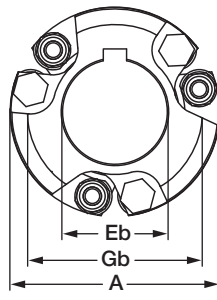

B Hub

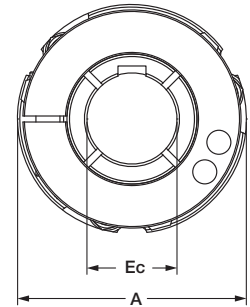
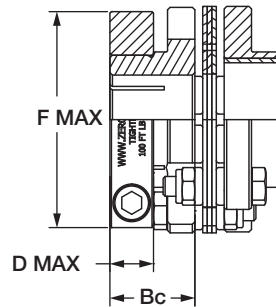

Dimensional Information

| | A | B A & B Hub | Bc C Hub | D Max. C Hub | F Max. C Hub | Max Bore | | | | Ga A Hub | Gb B Hub | H | X | C min. (DBSE) |
|---------------|-----------------|----------------|----------------|-----------------|-----------------|---------------|---------------|----------------------|------------------------|-----------------|-----------------|----------------|----------------|------------------|
| | | | | | | Set Screw Hub | | Clamp Hubs | | | | | | |
| | Inch (mm) | Inch (mm) | Inch (mm) | Inch (mm) | Inch (mm) | Ea A Hub | Eb B Hub | Ec C Hub w/kwy | Ec C Hub w/o kwy | Inch (mm) | Inch (mm) | Inch (mm) | Inch (mm) | Inch (mm) |
| 6F22 6F22C | 2.25 (57.2) | 0.94 (23.8) | 1.00 (25.4) | 0.551 (14) | 2.21 (56) | 0.625 (16) | 1.000 (26) | 0.75 (20) | 0.938 (25) | 1.22 (31.0) | 1.88 (47.6) | 0.91 (23.1) | 0.51 (13.0) | 3.00 (76.2) |
| 6F26 6F26C | 2.59 (65.8) | 1.06 (27.0) | 1.06 (27.0) | 0.551 (14) | 2.36 (60) | 0.750 (19) | 1.250 (32) | 1.00 (24) | 1.188 (30) | 1.50 (38.1) | 2.16 (54.8) | 1.00 (25.4) | 0.39 (9.9) | 3.00 (76.2) |
| 6F30 6F30C | 3.00 (76.2) | 1.25 (31.8) | 1.25 (31.8) | 0.709 (18) | 2.92 (74) | 1.000 (25) | 1.375 (35) | 1.125 (30) | 1.375 (35) | 1.71 (43.4) | 2.50 (63.5) | 1.21 (30.7) | 0.39 (9.9) | 3.68 (93.7) |
| 6F37 6F37C | 3.75 (95.3) | 1.44 (36.5) | 1.44 (36.5) | 0.748 (19) | 3.71 (94) | 1.250 (32) | 1.813 (46) | 1.500 (38) | 1.875 (48) | 2.19 (55.6) | 3.13 (79.4) | 1.51 (38.4) | 0.68 (17.3) | 4.5 (114.3) |
| 6F45 6F45C | 4.50 (114.3) | 1.69 (42.9) | 1.69 (42.9) | 0.866 (22) | 4.29 (109) | 1.625 (42) | 2.250 (60) | 1.75 (45) | 2.25 (55) | 2.69 (68.3) | 3.75 (95.3) | 1.81 (46.0) | 0.91 (23.1) | 5.50 (139.7) |
| 6F52 6F52C | 5.25 (133.4) | 1.94 (49.2) | 1.94 (49.2) | 0.984 (25) | 4.92 (125) | 1.875 (45) | 2.625 (66) | 2.25 (60) | 2.625 (65) | 3.31 (84.1) | 4.38 (111.1) | 2.10 (53.3) | 0.73 (18.5) | 6.5 (165.1) |
| 6F60 6F60C | 6.00 (152.4) | 2.44 (61.9) | 2.44 (61.9) | 1.339 (34) | 5.71 (145) | 2.250 (60) | 3.000 (76) | 2.62 (70) | 3.000 (75) | 3.67 (93.2) | 5.00 (127.0) | 2.42 (61.5) | 0.69 (17.5) | 7.00 (178) |
| 6F67 6F67C | 6.75 (171.5) | 2.75 (69.9) | 2.75 (69.9) | 1.339 (34) | 6.50 (165) | 2.625 (65) | 3.375 (85) | 2.875 (80) | 3.50 (90) | 4.29 (109.0) | 5.63 (142.9) | 2.72 (69.1) | 0.41 (10.4) | 8.00 (203) |

- Dimension L is equal to (2x B) + C (C is the DBSE or span)
- Dimension C is always manufactured to application requirements
- "X" dimension is minimum bolt travel required beyond the hub to disassemble disc packs from the hubs.

CD[®] COUPLINGS **FLOATING SHAFT**

Table below shows lengths and speeds at which standard floating shaft couplings can operate while avoiding natural frequencies. Couplings at or near table values may require dynamic balancing. See below for balancing information. Should your application fall outside these parameters, consult factory. Special construction of the disc pack or floating shaft can increase speeds and/or maximum lengths. Refer to coupling misalignment information below.

| Maximum Span C | | | | | | | | | | |
|----------------|-----------------|-----------------|-----------------|------------------|------------------|------------------|------------------|------------------|------------------|------------------|
| | 2,250 RPM | 2,000 RPM | 1,750 RPM | 1,500 RPM | 1,250 RPM | 1,000 RPM | 900 RPM | 750 RPM | 650 RPM | 500 RPM |
| | Inch (mm) | Inch (mm) | Inch (mm) | Inch (mm) | Inch (mm) | Inch (mm) | Inch (mm) | Inch (mm) | Inch (mm) | Inch (mm) |
| 6F22 6F22C | 46.9 (1,193) | 49.8 (1,265) | 53.2 (1,352) | 57.5 (1,461) | 63.0 (1,600) | 70.4 (1,789) | 74.2 (1,886) | 81.3 (2,066) | 87.4 (2,219) | 99.6 (2,530) |
| 6F26 6F26C | 52.5 (1,332) | 55.6 (1,413) | 59.5 (1,511) | 64.2 (1,632) | 70.4 (1,787) | 78.7 (1,998) | 82.9 (2,107) | 90.9 (2,308) | 97.6 (2,479) | 111.3 (2,826) |
| 6F30 6F30C | 52.5 (1,332) | 55.6 (1,413) | 59.5 (1,511) | 64.2 (1,632) | 70.4 (1,787) | 78.7 (1,998) | 82.9 (2,107) | 90.9 (2,308) | 97.6 (2,479) | 111.3 (2,826) |
| 6F37 6F37C | 51.0 (1,295) | 67.3 (1,709) | 75.4 (1,915) | 81.4 (2,068) | 89.2 (2,266) | 99.7 (2,533) | 105.1 (2,670) | 115.2 (2,925) | 123.7 (3,142) | 141.0 (3,582) |
| 6F45 6F45C | 59.5 (1,511) | 79.2 (2,012) | 84.9 (2,157) | 91.7 (2,330) | 100.5 (2,553) | 112.4 (2,854) | 118.4 (3,008) | 129.7 (3,295) | 139.4 (3,540) | 158.9 (4,036) |
| 6F52 6F52C | 25.8 (655) | 38.7 (983) | 57.6 (1,463) | 86.7 (2,202) | 105.5 (2,681) | 118.0 (2,997) | 124.4 (3,159) | 136.3 (3,461) | 146.4 (3,718) | 166.9 (4,239) |
| 6F60 6F60C | 33.2 (843) | 49.0 (1,245) | 71.8 (1,824) | 103.0 (2,616) | 112.8 (2,866) | 126.1 (3,204) | 133.0 (3,377) | 145.7 (3,700) | 156.5 (3,974) | 178.4 (4,531) |
| 6F67 6F67C | 32.5 (826) | 49.3 (1,252) | 73.9 (1,877) | 111.8 (2,840) | 124.0 (3,150) | 138.7 (3,522) | 146.2 (3,713) | 160.1 (4,067) | 172.0 (4,369) | 196.1 (4,981) |



Dynamic Balancing Guidelines for CD Floating Shaft Couplings

The close tolerances used to manufacture CD Couplings in conjunction with the composite disc pack make CD Floating Shaft Couplings especially well suited to high speed and long span applications. Occasionally, the application may require dynamic balancing of the floating shaft coupling. See graph for general application guidelines.

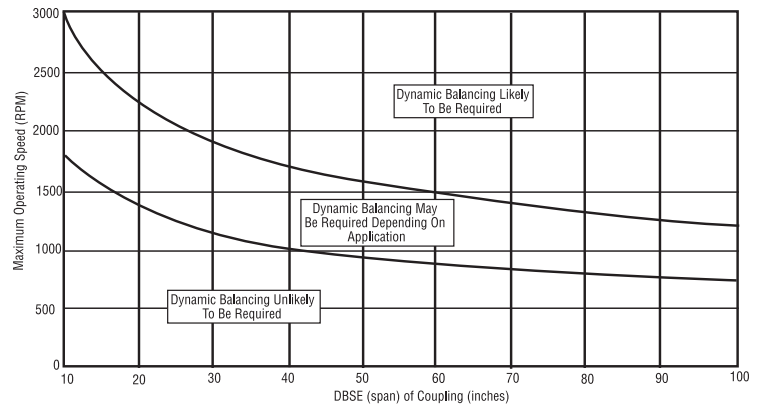

Coupling Misalignment

In general, the misalignment capacity of CD Floating Shaft Couplings is related to the speed at which they operate and the mass of the floating shaft, which is governed by its diameter and length. The table to the right shows recommended maximum allowable angular misalignment:

By reducing the allowable misalignment (and therefore stresses in the discs) at higher operating speeds and longer DBSEs, the disc pack can better support and stabilize the floating shaft, which will result in longer coupling life, smoother operation, and less vibration to the connected equipment. Call us for application assistance.

| DBSE (Distance "C") | | | |
|---------------------|-----------|-----------|----------|
| | Up to 30" | 30" - 60" | OVER 60" |
| To 500 RPM | 3° | 2.5° | 2° |
| 500-1,000 RPM | 2.5° | 2° | 1.5° |
| 1,000-1,500 RPM | 2° | 1.5° | 1° |
| Above 1,500 RPM | 1° | 0.75° | 0.50° |

CD[®] COUPLINGS *SPACER and FLOATING SHAFT SPECIALS*

For long spans between motion components, special CD spacer or floating shaft couplings are the answer.

Any of the hub options (A, B and Clamp style) shown in this catalog are available.

Special spacer materials are available including aluminum, steel, and stainless steel.

Special finishes to shaft and hub components are available including nickel plating, and others.

Call Zero-Max for recommendations.

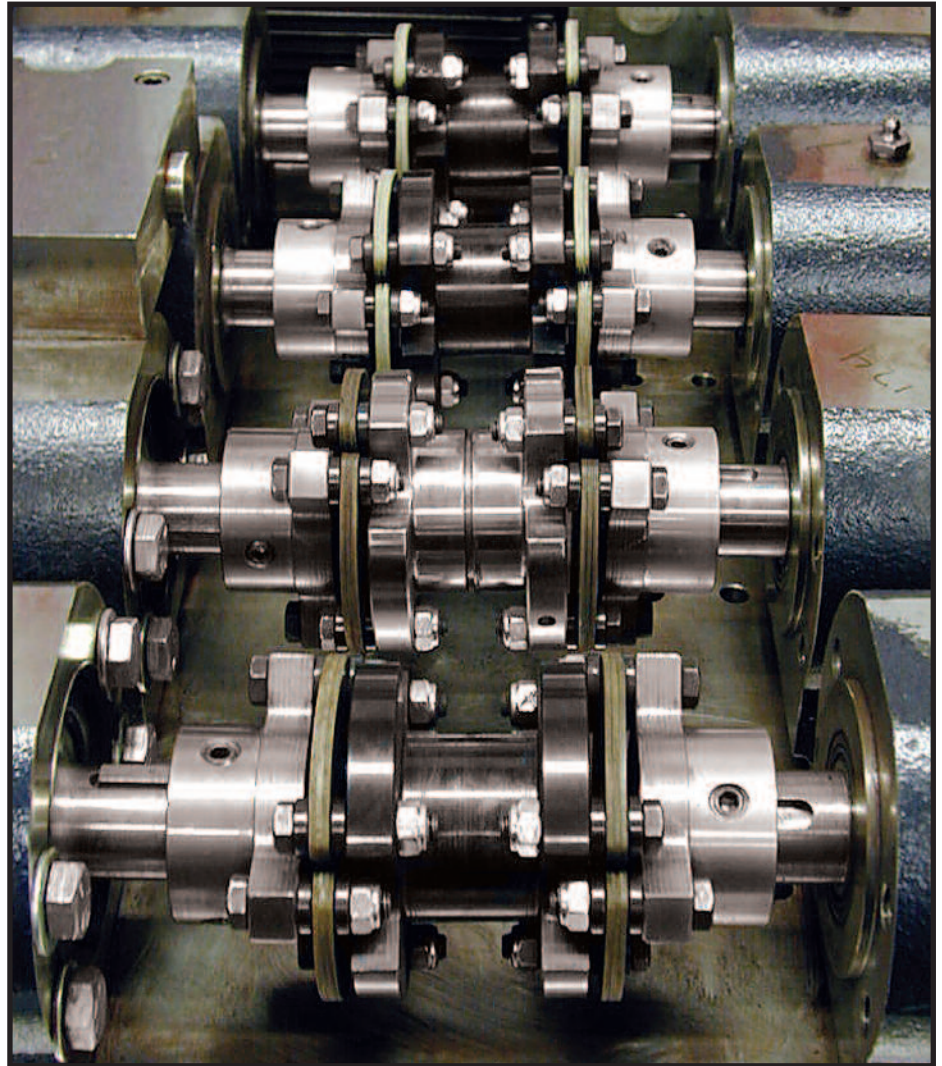

Double Flex spacer couplings on test in the Zero-Max test lab. This system is designed to run continuously at high misalignment, subjecting the composite unitized disc packs to billions of flexural fatigue cycles.

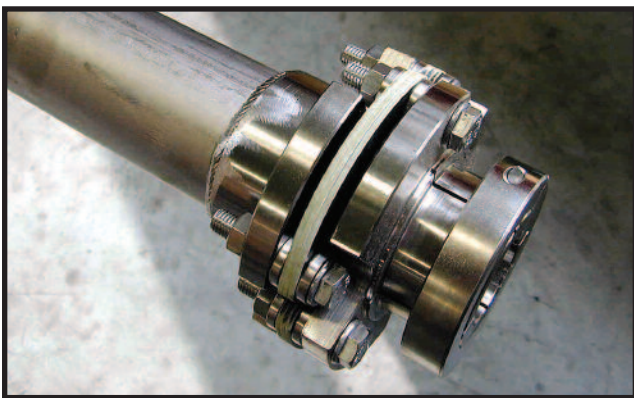

Clamp style hubs on the Composite Disc Floating Shaft Coupling provide an effective and secure shaft engagement.



Nickel plated CD Floating Shaft Coupling provide effective corrosion protection.

CD® COUPLINGS SPECIALS

Custom designs.

No application is too large, too small, or too difficult for a CD coupling. Zero-Max has the ability to provide imaginative solutions for virtually every coupling need.

Design Engineering Assistance.

From the first contact you have with our factory trained and supported Representative, to the completion of the approval drawing, Zero-Max will provide quality service throughout the process. Zero-Max Engineering is continually involved in custom projects with the latest technology available to solve your coupling needs. Our recommendations are based on decades of coupling experience.

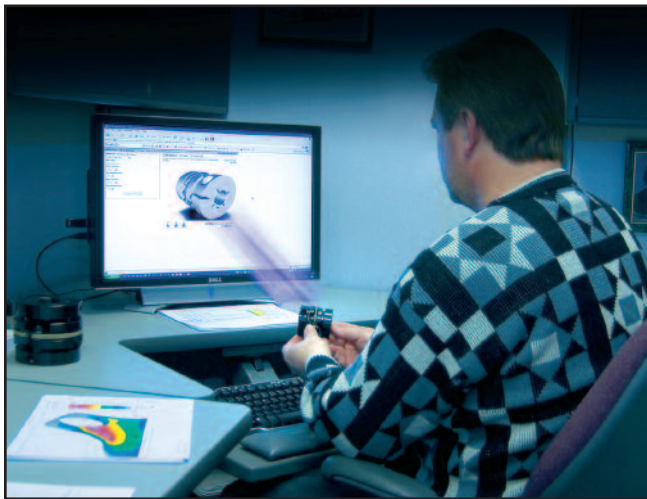

Need higher misalignment and greater torque capacity in your coupling? Need more flexibility and torsional stiffness too? Need to fit a high performance coupling in a really small space? Need a really large bore diameter coupling or a very long spacer coupling? It is likely that a standard CD Coupling will satisfy your requirements. If it doesn't, we'll quickly design a solution using our finite element analysis (FEA). With experience at thousands of different applications, our extensive FEA database brings instant answers to your questions.



Key Is The Patented Disc Design.

The key to the high performance capabilities of the CD coupling lies in the Composite Disc pack. Everything about this unique part contributes to its high performance characteristics. The shape, the cutting process, the material used, the order and the

orientation of the layers, and even the coating used have an important significance.

Zero-Max has been perfecting this design since the mid 80's and has accumulated a vast database of solutions.

Finite Element Analysis Tailors Disc to Application.

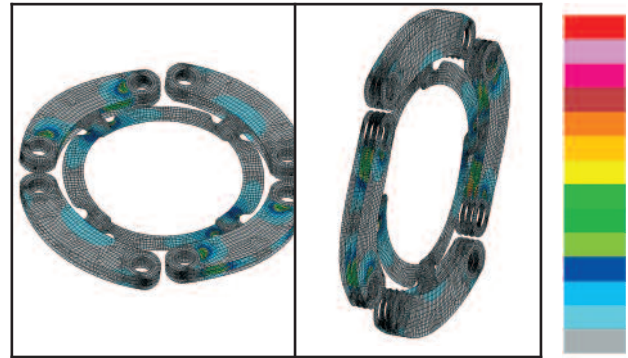

Using finite element analysis (FEA), the disc design can be easily modified along with changes in the composite material. Custom disc designs (manufactured on state-of-the-art laser cutting machines) can add to or lessen coupling flexibility or increase strength and stiffness as required for the particular application. There are over

40 standard models and sizes of

CD couplings for most applications.

For applications outside this range, CD Couplings can be designed and produced cost effectively within your delivery requirements.

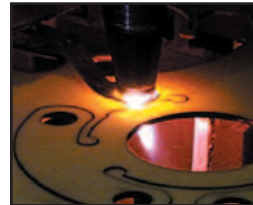

Design, Analysis, Testing Programs, and Production Capabilities are all geared toward supplying the correct coupling at the lowest cost and in the shortest lead time.

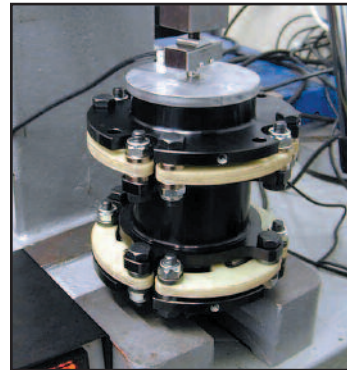

Coupling Axial Stiffness Test

The Zero-Max test laboratory is capable of all types of static and dynamic testing to insure that the design specifications are met.

Production of CD Couplings is executed with modern CNC machinery, which provides components with the accuracy required for demanding applications. Quality Control of all manufacturing processes, guarantees that CD Couplings will meet strict performance requirements.

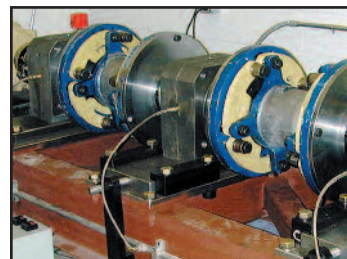

Full scale durability test of two wind generator couplings under extreme misalignment conditions.

Zero-Max is ISO 9001:2000 certified.

CD® COUPLINGS SPECIALS

High Power in a small space

This allowed our customer to use a smaller machine base!



High Speed Couplings

This coupling uses low inertia designed hubs for exceptionally high speed applications.



Large Scale Floating Shaft Couplings

High Power Wind Turbines require long life and superior flexibility.



High Misalignment and High Torque

Composite materials of disc packs offer longer life and higher performance than Stainless disc packs.



Custom Stiffness

Custom Disc pack and hubs to meet critical application.



Shrink Disc Clamping Hubs

Special hubs for high torque keyless shaft applications.



QD Bushing Couplings

Single flex coupling has machined hub to accept standard QD bushing.



Phase Adjustable Couplings

Special double flex coupling has built-in phase adjuster for use in printing presses.



Blind Fit Couplings

Coupling is designed so assembly of two fixed shafts is possible without disassembly of the components.

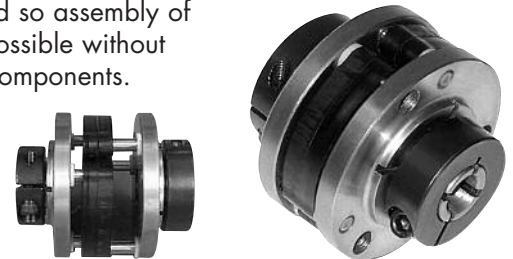

Before and After Assembly

High Misalignment and High Torque

Composite materials of disc packs offer longer life than Stainless disc packs.



CD® COUPLINGS **SPECIALS**

Nickel Plated Couplings

For applications requiring frequent washdowns.

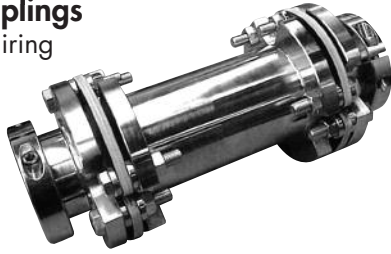

Torque Transducer Coupling

Special spacer coupling has built-in torque transducer for use on a test fixture.

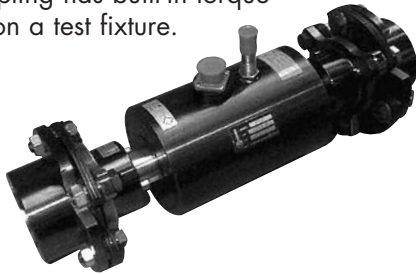

Aluminum Floating Shaft Couplings

For high speed operation.



Large Scale Floating shaft

For large scale printing application. Very high torsional stiffness.



High Precision in a small package

Double flex, clamp hubs only 1.6" wide!



Modified Discs For Increased Performance.

Zero-Max is committed to excellence and complete customer satisfaction. Every custom CD coupling must first exceed our performance expectations before production and delivery to you, our customer.

Call today to discuss your custom CD Coupling needs 800-533-1731.

Longer Arm Design Yields Greater Coupling Flexibility



Shorter Arm Design Yields Greater Coupling Rigidity



Custom 12 bolt design
Ultra high torsional stiffness with flexibility.



Custom Disc Packs
To meet our customer designs and mount directly to custom driveline components



SELECTING THE RIGHT CD COUPLING

Information Required

- Service factor.
- Continuous and peak torque requirements, and/or motor HP.
- Coupling RPM.
- Distance between shaft ends. (DBSE).
- Misalignment requirements.
- Physical space limitations.
- Hub bores, with or without keyways.
- Other environmental considerations.

Selection Procedure

1. Select a coupling type (Single Flex, Double Flex, Spacer or Floating Shaft) based on misalignment and/or DBSE (Distance Between Shaft Ends).
2. Determine the required service factor; please refer to the chart on the next page.
3. If continuous torque is known, then multiply it by the required service factor to get the design torque:
Design Torque (in-lbs) = Continuous Torque (in-lbs) x Service Factor
 If continuous torque is not known, but Horsepower and RPM are, calculate the design torque by using this formula:
Design Torque (in-lbs) = $\frac{HP \times 63,000 \times Service\ Factor}{Coupling\ RPM}$
4. Select a coupling size that has a continuous torque rating greater than the Design Torque calculated in step 3. Make sure that the peak torque of the application does not exceed the maximum torque rating of the coupling.
5. Check Coupling RPM to be sure it is within the rated maximum speed. Consult with factory if your speed exceeds the ratings – We have made many special couplings that greatly exceed these ratings.
6. Make sure that the misalignment capability is sufficient. As with all couplings, there is a trade-off between the parallel, axial and angular misalignment capabilities. Be certain that the **combined percentages** of each do not exceed 100%. *If you have a question on combined misalignments, consult the factory.* It is always best to select a coupling with misalignment capabilities exceeding the initial operating conditions to allow for changing conditions over the operating life of the machine.
7. Check to be sure that the coupling fits the required dimensions such as available space envelope and bore sizes.
8. If the coupling size and type meet the torque, misalignment, space envelope criteria, the selection is complete.

Note: If the standard couplings listed in the catalog do not meet your requirements, please consult the factory. We will work with you to meet your needs.



Single



Double



Floating Shaft



Call Factory for Customs

HOW TO ORDER

Determine the complete model code and the bore sizes, see example.

- For the clamp style, indicate if a keyway is needed.

Note: If no callout is made the hub will have a keyway.

- Contact factory if any options such as dynamic balancing, special DBSE (Distance Between Shaft Ends), special materials such as stainless steel or nickel plating, special bore tolerances, non-standard key sizes, etc.

- Please reference the charts below regarding standard key sizes.

Example 6P45C (30mm w/o key, 1.25" with key)

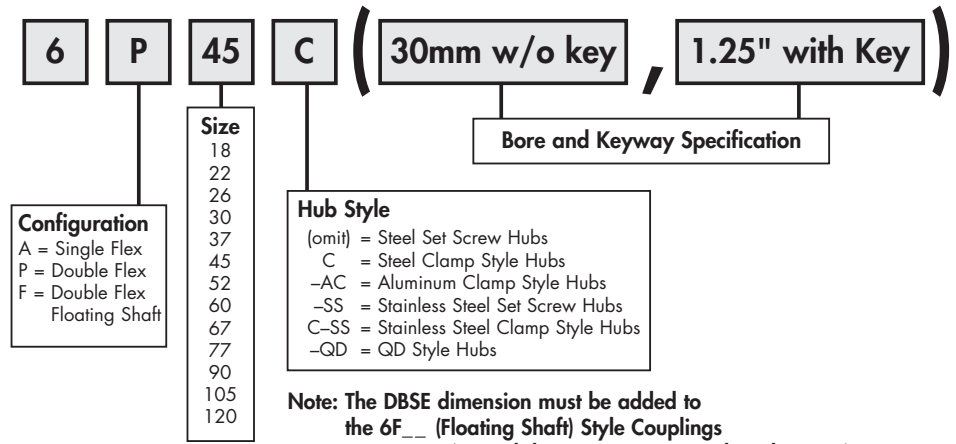

Based on nominal shaft diameter (AGMA Standard 511.02) Clearance Fit Standard. Metric hub bores will be supplied with H7 clearance fit as standard. S7 interference fit available.

Standard Keyways

Inch Bore Hubs

| Bore Size | | Keyway | Bore Size | | Keyway |
|-----------|-------|---------------|-----------|-------|---------------|
| Over | To | | Over | To | |
| 0.437 | 0.562 | 0.125 x 0.062 | 2.250 | 2.750 | 0.625 x 0.312 |
| 0.562 | 0.875 | 0.187 x 0.094 | 2.750 | 3.250 | 0.750 x 0.375 |
| 0.875 | 1.250 | 0.250 x 0.125 | 3.250 | 3.750 | 0.875 x 0.437 |
| 1.250 | 1.375 | 0.312 x 0.156 | 3.750 | 4.500 | 1.000 x 0.500 |
| 1.375 | 1.750 | 0.375 x 0.187 | 4.500 | 5.500 | 1.250 x 0.625 |
| 1.750 | 2.250 | 0.500 x 0.250 | 5.500 | 6.500 | 1.500 x 0.750 |

Note: Inch bore hubs will be supplied with inch size setscrews.

Standard Keyways

Metric Bore Hubs

| Bore Size | | Keyway | Bore Size | | Keyway |
|-----------|----|----------|-----------|-----|----------|
| Over | To | | Over | To | |
| 10 | 12 | 4 x 1.8 | 58 | 65 | 18 x 4.4 |
| 12 | 17 | 5 x 2.3 | 65 | 75 | 20 x 4.9 |
| 17 | 22 | 6 x 2.8 | 75 | 85 | 22 x 5.4 |
| 22 | 30 | 8 x 3.3 | 85 | 95 | 25 x 5.4 |
| 30 | 38 | 10 x 3.3 | 95 | 110 | 28 x 6.4 |
| 38 | 44 | 12 x 3.3 | 110 | 130 | 32 x 7.4 |
| 44 | 50 | 14 x 3.8 | 130 | 150 | 36 x 8.4 |
| 50 | 58 | 16 x 4.3 | 150 | 170 | 40 x 9.4 |

Note: Metric bore hubs will be supplied with metric size setscrews

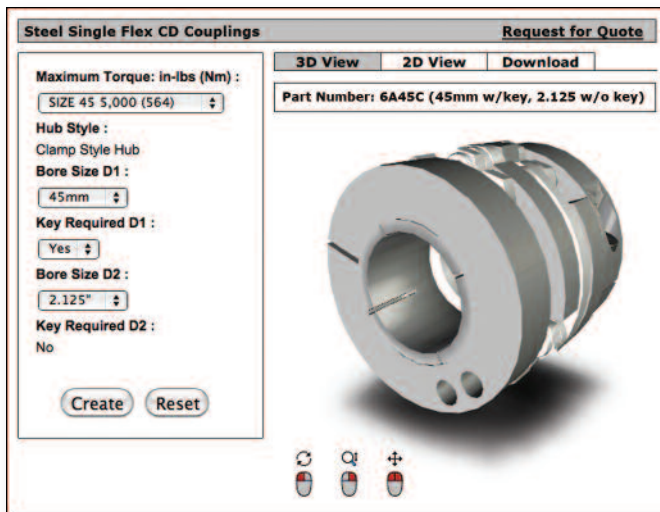

New Zero-Max Configurable 3D CAD Downloads.
www.zero-max.com



ServoClass® Couplings

Designed for demanding servomotor applications. Zero backlash, high torsional stiffness coupling. Features flexible metal discs and keyless clamp-type mounting hubs. Couplings are RoHS compliant.



ETP® Shaft Locking Connections

Designed for quick, easy and accurate assembly of mounted shaft components. Both inch and metric bore connections are available from stock.



CD® Couplings

These high performance couplings **out last** bellows and steel disc design couplings. The unique design of the composite disc enables the CD Couplings® to withstand punishing applications and deliver high precision performance.



Roh'Lix® Linear Actuators

Roh'Lix® Linear Actuators convert rotary motion into precise linear motion. Available in five models. Roh'Lix® actuators have thrust ratings from 5 to 200 lbs. All models feature built in overload protection.



Schmidt Offset Couplings®

Schmidt Offset Couplings® are designed to handle high amounts of parallel offset up to 17.00". Standard models with torque capacities up to 459,000 in-lbs.



Adjustable Speed Drive

Easy to install and maintenance free. Zero-Max Drives offer infinitely variable speeds from 0 rpm to 1/4 of input rpm. 5 models with torque ranges from 12 in-lbs to 200 in-lbs.

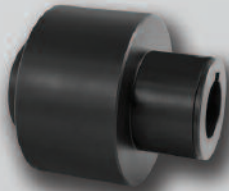

Overload Safety Couplings

Torq-Tender® Couplings provide reliable overload protection in any mechanical power transmission system. Torque ranges from 2 to 3000 in-lbs.

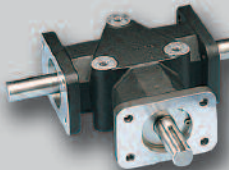

Crown Gear Drives

Crown Gear Drives® are available with 1:1 and 2:1 ratios. High quality AGMA class 10 spiral bevel gears. Stainless steel shafts and aluminum housings are standard on all Crown Gear Drives®.



Control-Flex® Couplings

Control-Flex® Couplings are zero backlash couplings designed for encoder and instrumentation type applications.



OHLA® Overhung Load Adapters

OHLA® Overhung Load Adapters are designed to eliminate radial and axial loads from a hydraulic pump or motor. 11 models available for mounts from SAE A to SAE F.

Warranty. Zero-Max, Inc. the manufacturer, warrants that for a period of 12 months from date of shipment it will repair, or at its option, replace any new apparatus which proves defective in material or workmanship, or which does not conform to applicable drawings and specifications approved by the manufacturer. All repairs and replacements shall be F.O.B. factory. All claims must be made in writing to the manufacturer. • In no event and under no circumstances shall manufacturer be liable for (a) damages in shipment; (b) failures or damages due to misuse, abuse, improper installation or abnormal conditions of temperature, dirt, water or corrosives; (c) failures due to operation, intentional or otherwise, above rated capacities, and (d) non-authorized expenses for removal, inspection, transportation, repair or rework. Nor shall manufacturer ever be liable for consequential and incidental damages, or in any amount greater than the purchase price of the apparatus. • Zero Max, Inc. reserves the right to discontinue models or to change specifications at any time without notice. No discontinuance or change shall create any liability on the part of Zero-Max, Inc. in respect to its products in the hands of customers or products on order not incorporating such changes even though delivered after any such change. • This warranty is in LIEU OF ALL OTHER WARRANTIES, EXPRESS OR IMPLIED, INCLUDING (BUT NOT LIMITED TO) ANY IMPLIED WARRANTIES OF MERCHANTABILITY OR FITNESS FOR A PARTICULAR PURPOSE. THE TERMS OF THIS WARRANTY CONSTITUTE ALL BUYER'S OR USER'S SOLE AND EXCLUSIVE REMEDY, AND ARE IN LIEU OF ANY RIGHT TO RECOVER FOR NEGLIGENCE, BREACH OF WARRANTY, STRICT TORT LIABILITY OR UPON ANY OTHER THEORY. Any legal proceedings arising out of the sale or use of this apparatus must be commenced within 18 months of the date of purchase. • CAUTION: Rotating equipment must be guarded. Also refer to OSHA specifications and recommendations. • Zero-Max®, CD®, ETP®, ServoClass®, Torq-Tender®, Control-Flex®, Posi-Lok®, Roh'Lix® and OHLA® are registered trademarks of Zero-Max, Inc. In U.S.A. © Zero-Max 2010 Printed in U.S.A.



DISTRIBUIDOR
AUTORIZADO

MEX (55) 53 63 23 31
QRO (442) 1 95 72 60

MTY (81) 83 54 10 18
ventas@industrialmagza.com

13200 Sixth Avenue North,
Plymouth, Minnesota 55441-5509
Phone: 800-533-1731 (763) 546-4300
Fax (763) 546-8260 www.zero-max.com